

# TRI-DENT

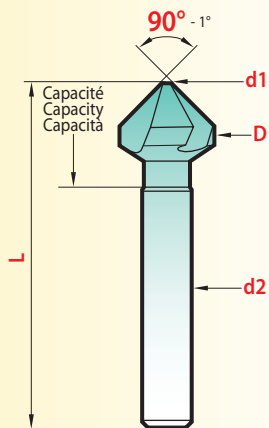

## Longs Largas Lunghe

90°

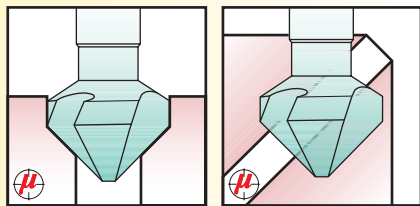
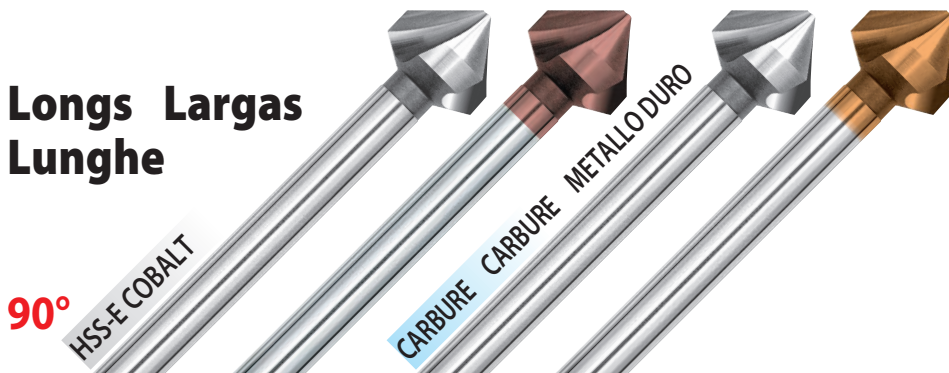

D	d1	d2	L	magafor 4303	Red'X 4933	magaforce 8431-L	Hard'X 8431-LH
z9	maxi	h9	± 1				
6,3	1,5	6	84	€ 35,01	€ 41,28	€109,72	€ 121,22
8,3	2,0	8	85	37,10	44,93	123,31 *	137,94*
10,4	2,5	10	87	39,71	49,11	159,88 *	178,69*
12,4	2,8	10	108	40,75	52,25	165,11 *	187,05*
16,5	3,2	12	112	48,07	64,79	194,37 *	218,40*
20,5	3,5	12	115	64,27	86,73	220,49 *	246,62*
25,0	3,8	12	118	87,26	120,17		

\* queue avec 3 plats 3 fluted shanks Mango con 3 planos Codolo con 3 piani

## Carbure Carbide Metallo duro

Les fraises **magaforce**, sont en CARBURE MONOBLOC. Cette conception leur confère une solidité unique.

The **magaforce** countersinks, are made from SOLID CARBIDE. This concept offers a unique strength.

Los avellanadores **magaforce**, están fabricados en METAL DURO INTEGRAL. Este concepto ofrece una rigidez única.

Le frese **magaforce**, sono in METALLO DURO INTEGRALE. Questa struttura conferisce loro una solidità unica.



Vidéo on line  
[www.magafor.com](http://www.magafor.com)

## Longs / Extra-longs Largas / X-largas Lunghe / Extra lunghe

90°

magafor standard

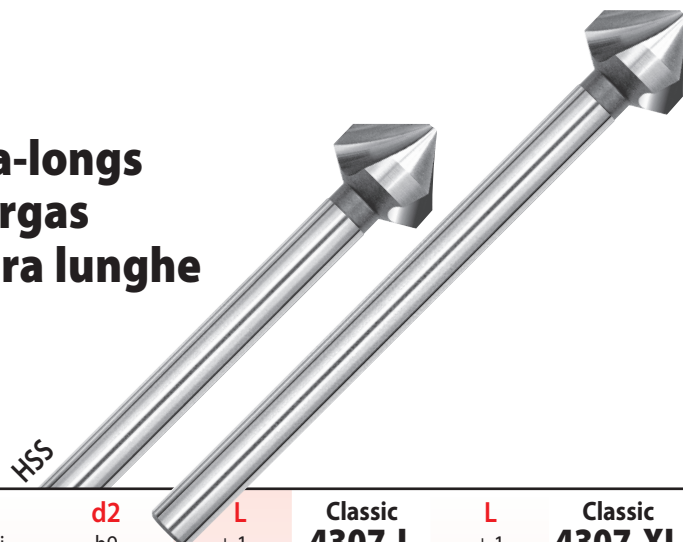

D	d1	d2	L	Classic 4307-L	L	Classic 4307-XL
z9	maxi	h9	± 1		± 1	
5,8	1,5	5	104	€ 35,53		€
6,3	1,5	5	104	35,53	154	46,50
8,3	2,0	6	105	36,57	155	47,55
10,4	2,5	6	107	37,62	157	49,11
12,4	2,8	8	108	38,66	158	50,68
15,0	3,2	10	109	41,80	159	54,86
16,5	3,2	10	111	42,84	161	55,91
20,5	3,5	10	114	58,00	164	75,24
25,0	3,8	10	118	78,38	168	101,36

 **magafor**, Le choix! The choice! La elección! La scelta!

Matière Werkstoff Materiale	HSS	HSS-E Cobalt	HSS-E Cobalt + TiN	HSS-E 8% Cobalt	HSS-E 8% Cobalt + Red'x	CARBURE CARBIDE METALLO DURO	CARBURE CARBIDE + Hard'X
Dureté Durezza	63 HRC	65HRC	65 HRC + 2300 HV	67 HRC	67 HRC + 3500 HV	1800 HV	1800 HV + 3500 HV
Utilisation Use/Small series Utilización Impiego	Petites séries Intensive production Pequeñas series Piccole serie	Production intensive Hard and abrasive alloys Producción intensiva Produzione intensiva		Alliages durs et abrasifs Treated steels Aleaciones duras y abrasivas Leghe dure e abrasive		Aciers trempés Aceros tratados Acciai temperati	
Page Pagina	48 - 50 - 51 - 55		47 ~ 57	49		49 ~ 56	