

FORETS À POINTER NC  
 NC SPOTTING DRILLS  
 BROCAS DE PUNTEAR CNC  
 PUNTE A CENTRARE NC

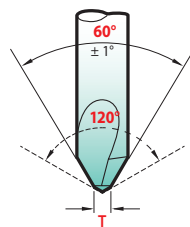

60°



magafor standard

α 60°

D	L	ℓ	T*	magafor 191	Red'X 0991
h6	± 1	+ 1		€	
4,0	52	12	0,8	47,02	52,25
5,0	60	15	0,9	49,64	54,86
6,0	66	20	1,0	52,25	60,09
8,0	79	25	1,3	54,86	65,31
10,0	89	25	1,6	57,47	70,54
12,0	102	30	2,0	62,70	78,38
16,0	115	35	3,0	94,05	117,56
20,0	131	40	3,5	156,75	193,32

\*T = angle ángulo Angulo 120°

Coupe à gauche  
 Left hand cut  
 Corte a izquierdas  
 Elica sinistra

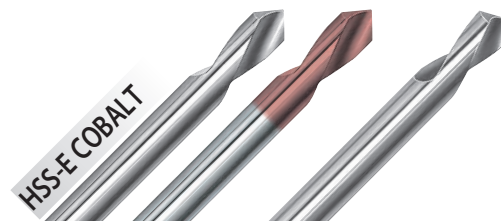

magafor standard

α 90°

90°

120°

D	L	ℓ	magafor 192	TiN 0992	magafor 193
h6	± 1	+ 1	€	€	€
3,0	50	10	26,13	31,35	26,13
4,0	52	12	31,35	36,57	31,35
5,0	60	15	36,57	41,80	36,57
6,0	66	20	41,80	49,64	41,80
8,0	79	25	47,02	57,47	47,02
10,0	89	25	52,25	65,31	52,25
12,0	102	30	62,70	78,38	
16,0	115	35	99,27	122,79	

Extra courts  
 Extra short  
 Extra cortas  
 Extra corta

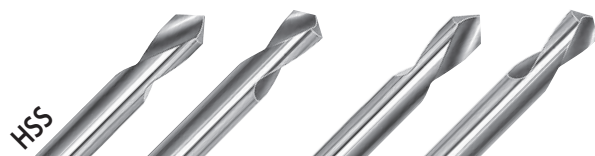

D h7		L	ℓ	Classic 19-A	Classic 19-B	Classic 19-AG	Classic 19-BG
inch	mm	± 1	+ 1	€	€	€	€
1/8"	3,17	32	9,5	9,40	9,40	15,60	15,60
3/16"	4,76	35	12,5	10,45	10,45	17,35	17,35
1/4"	6,35	38	16	12,28	12,28	20,40	20,40
5/16"	7,93	38	16	13,06	13,06	21,70	21,70
3/8"	9,52	51	25,5	14,63	14,63	24,30	24,30
7/16"	11,11	51	25,5	18,03	18,03		
1/2"	12,7	51	25,5	21,68	21,68	36,00	36,00
5/8"	15,87	57	28,5	29,52	29,52	49,10	49,10
3/4"	19,05	57	28,5	60,09	60,09	99,75	99,75
7/8"	22,22	64	32	80,99	80,99		
1"	25,4	64	32	89,35	89,35	148,30	148,30

**Queue cône Morse**  
**Morse taper shank**  
**Mango**  
**Cono Morse**



D h10	L ±1	ℓ1 +1	ℓ2 +1	MORSE N°	90°		120°	
					magafor 198	€	magafor 1906	€
10,0	130	25	64	1	88,30	€	102,93	€
12,0	130	30	64	1	92,48		127,49	
16,0	148	35	68	2	113,90		151,52	
20,0	148	40	68	2	135,85		206,91	
25,0	171	45	72	3	187,05			

magafor

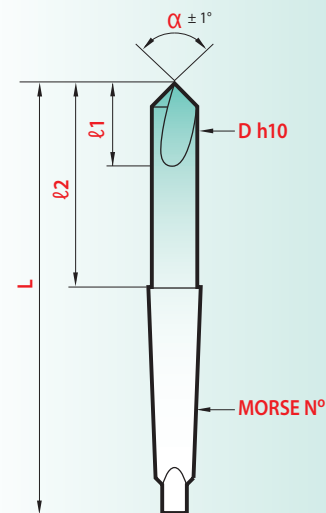

**OUTILS MULTI-FONCTIONS**  
**MULTI-FUNCTION TOOLS**  
**HERRAMIENTAS MULTI-FUNCIÓN**  
**UTENSILI MULTI-FUNZIONE**

*Promo-kits*



6 COMBI-mag Ø 4 - 5 - 6 - 8 - 10 - 12  
**007** €143,16



90°

COMBI-mag

inch	D h7 mm	L ±1	ℓ +1	T*	Red'X 007
	3	50	6	0,3	€ 16,20
1/8"	3,17	50	6	0,3	16,20
	4	52	8	0,4	16,72
3/16"	4,76	60	9	0,5	17,24
	5	60	10	0,5	17,24
	6	66	12	0,6	20,38
1/4"	6,35	66	12	0,6	21,42
5/16"	7,93	79	14	0,8	23,77
	8	79	14	0,8	23,77
3/8"	9,52	89	16	1	27,17
	10	89	16	1	28,21
	12	102	18	1,2	36,57
1/2"	12,7	102	19	1,3	38,66
	14	115	21	1,4	51,73
5/8"	15,87	115	24	1,6	53,82
	16	115	24	1,6	53,82

\*T = 0,1 D Épaisseur d'âme Web thickness Espesor del núcleo Spessore in punta del nocciolo

**COMBI-mag**

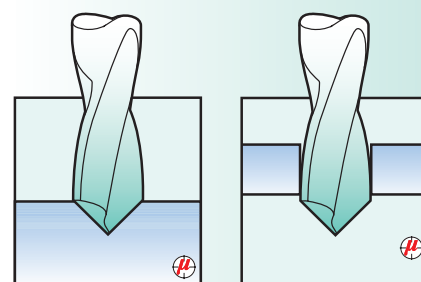

POINTAGE  
 SPOTTING  
 PUNTEADO  
 CENTRATURA

PERÇAGE  
 DRILLING  
 TALADRADO  
 FORATURA

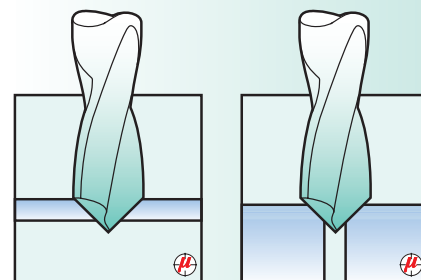

CHANFREIN DIRECT  
 DIRECT CHAMFER  
 CHAFLANES DIRECTOS  
 SVASATURA RAPIDA

CHANFREINAGE  
 COUNTERSINKING  
 AVELLANADO  
 SMUSSATURA

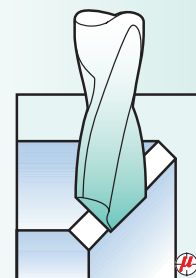

CHANFREIN LONGITUDINAL  
 LONGITUDINAL CHAMFER  
 CHAFLANES LONGITUDINALES  
 SMUSSI LONGITUDINALI