

H7 MACHINE REAMERS SPIRAL 10°

The left hand spiral combined with the right hand cut, behaves like an Archimedes screw:

- the coolant is fed directly to the cutting edges for better lubrication and cooling,
- the chips are pushed ahead with no risks of scratching the reamed hole.

Reamers designed to machine through holes to get best surface finish.

Nota: blind holes, see page 110 and 113.

ESCARIADORES MAQUINA H7 HÉLICE 10°

La hélice a izquierdas combinada con el corte a derecha actúa como un tornillo de Arquímedes:

- el refrigerante es dirigido directamente al filo de corte para una mejor lubricación y refrigeración,
- la viruta es empujada hacia delante sin riesgo de dañar el agujero ya escariado.

Escariadores diseñados para mecanizar agujeros pasantes y obtener unos excelentes acabados superficiales.

Nota: agujeros ciegos, ver página 110 y 113.

螺旋角 10° H7 机用铰刀

右切左螺旋犹如阿基米得螺旋 线原理:

- 冷却液直接导入切削区保证了良好的润滑和冷却
- 铁屑向前推出, 避免了刮伤已加工表面

铰刀设计成通孔加工以获得最好的表面光洁度。

盲孔请参考第110-113页。

SET JUEGO 套装

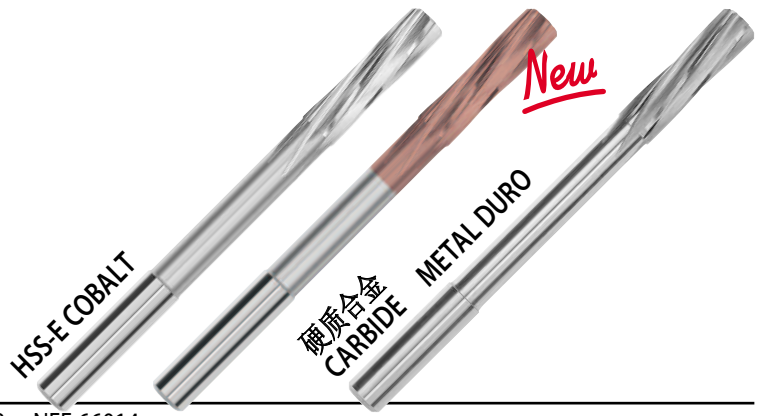

≈ DIN 212-B ≈ NFE 66014

D H7 inches	D H7 0,1 mm	L	l1	l2	d2 h8	magafor 650	Red'X 6509	magaforce 8650*
	1,0	38	7	22	D	€ •	€ •	€ •
	1,1 ~ 1,5	40	10	24	D	•	•	•
	1,6 - 1,7	43	11	25	D	•	•	•
	1,8 - 1,9	49	12	31	D	•	•	•
	2,0	49	12	31	D	•	•	•
	2,1 ~ 2,3	49	12	31	D	•	•	•
	2,4 ~ 2,9	57	18	38	D	•	•	•
	3,0	57	18	38	D	•	•	•
3,175 (1/8")	3,1 ~ 3,7	57	18	38	D	•	•	•
	3,8 - 3,9	75	19	51	4	•	•	•
	4,0	75	19	51	4	•	•	•
	4,1 - 4,2	75	19	51	4	•	•	•
	4,3 ~ 4,7	80	21	55	4,5	•	•	•
4,762 (3/16")	4,8 - 4,9	86	23	60	5	•	•	•
	5,0	86	23	60	5	•	•	•
	5,1 ~ 5,3	86	23	60	5	•	•	•
	5,4 ~ 5,8	93	26	66	5,5	•	•	•
	5,9	101	28	73	6	•	•	•
	6,0	101	28	73	6	•	•	•
6,35 (1/4")	6,1 ~ 6,7	101	28	73	6	•	•	•
	6,8 ~ 7,5	109	31	80	7	•	•	•
7,937 (5/16")	7,6 ~ 7,9	117	33	86	8	•	•	•
	8,0	117	33	86	8	•	•	•
	8,1 ~ 8,5	117	33	86	8	•	•	•
9,525 (3/8")	8,6 ~ 9,5	125	36	91	9	•	•	•
	9,6 ~ 9,9	133	38	99	10	•	•	•
	10,0	133	38	99	10	•	•	•
11,112 (7/16")	10,1 ~ 11,3	133	38	99	10	•	•	•
	11,4 ~ 11,9	151	44	106	12	•	•	•
	12,0	151	44	106	12	•	•	•
12,7 (1/2")	12,5 - 13,0	151	44	106	12	•	•	•
	13,5 - 14,0	160	47	110	14	•	•	•
14,287 (9/16")	14,5 - 15,0	162	50	112	14	•	•	•
15,875 (5/8")	15,5 - 16,0	170	52	117	16	•	•	•
	16,5 - 17,0	175	54	122	16	•	•	•
	17,5 - 18,0	182	56	129	16	•	•	•
19,05 (3/4")	18,5 - 19,0	189	58	136	16	•	•	•
	19,5 - 20,0	195	60	142	16	•	•	•

* Metal duro integral: Ø 1,0 - 13,0 / Cabeza metal duro soldada: Ø 14,0 - 20,0
Solid carbide: Ø 1,0 - 13,0 / Brazed carbide head: Ø 14,0 - 20,0
整体合金: Ø 1,0 - 13,0 / 头部焊接合金: Ø 14,0 - 20,0

	8 PIECES	PIEZAS	支	61 PIECES	PIEZAS	支
COMPOSITION COMPOSICIÓN 套装	Ø 2-3-4-5-6-8-10-12			Ø 2,0 ~ 8,0 by por 间隔 0,1mm		
magafor	650/1	€	•	650/2	€	•
magaforce	8650/1	€	•	8650/2	€	•

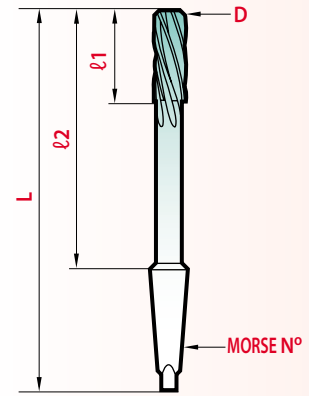
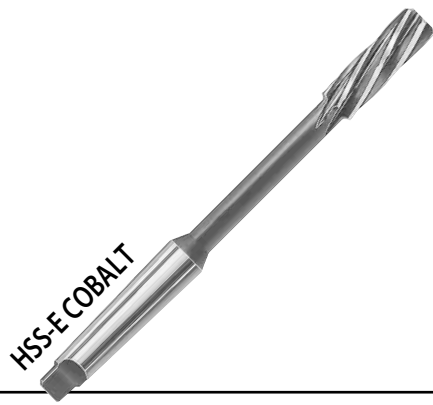

DIN 208-B • NFE 66015

D H7 inches	D H7 mm	L	ℓ1	ℓ2	MORSE N°	magafor 660
	4,0	120	19	54	1	€ •
	5,0	125	26	59	1	•
	6,0	138	26	72	1	•
6,35 (1/4")	6,5	144	28	84	1	•
	7,0 - 7,5	150	31	84	1	•
7,937 (5/16")	8,0 - 8,5	156	33	90	1	•
	9,0 - 9,5	162	36	96	1	•
9,525 (3/8")	10,0 - 10,5	168	38	102	1	•
11,112 (7/16")	11,0 - 11,5	175	41	109	1	•
	12,0	182	44	116	1	•
12,7 (1/2")	12,5 - 13,0	182	44	116	1	•
	13,5 - 14,0	189	47	123	1	•
14,287 (9/16")	14,5 - 15,0	204	50	124	2	•
15,875 (5/8")	15,5 - 16,0	210	52	130	2	•
	16,5 - 17,0	214	54	134	2	•
	17,5 - 18,0	219	56	139	2	•
	18,5 - 19,0	223	58	143	2	•
19,05 (3/4")	19,5 - 20,0	228	60	148	2	•
	20,5 - 21,0	232	62	152	2	•
22,225 (7/8")	21,5 - 22,0	237	64	157	2	•
	22,5 - 23,0	241	66	161	2	•
	24 - 25	268	68	168	3	•
25,4 (1")	26	273	70	173	3	•
	27 - 28	277	71	177	3	•
	29 - 30 - 31	281	73	181	3	•
	32	290	77	190	3	•
	33 - 34 - 35	321	78	197	4	•
	36 - 37	325	79	201	4	•
	38 - 39 - 40	329	81	205	4	•
	41 - 42	333	82	209	4	•
	43 - 44 - 45	336	83	212	4	•
	46 - 47	340	84	216	4	•
	48 - 49 - 50	344	86	220	4	•
	55	344	86	220	4	•
	60	344	86	220	4	•

Flute number
Número de dientes
刀数

z	650 / 6509 ∅	8650 ∅	660 ∅
4	1,0	1,0 ~ 2,3	
6	1,1 ~ 12,5	2,4 ~ 13,0	4,0 ~ 13,0
8	≥ 12,7	≥ 13,5	13,5 ~ 25,0
10			25,4 ~ 38,0
12			39,0 ~ 60,0

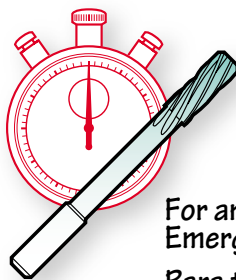

For any dimension not on the list or for special tolerances:
Emergency 48-hour Service. Page 123.

Para todas las dimensiones no tarifadas o tolerancias especiales:
Servicio Urgente 48 horas. Página 123.

任何不在列表中的特殊公差要求:
48小时紧急交货服务. 页123