

# Bi-face-R

**Bi-face-R** radius cutters have a constant relief profile which results in a high quality surface finish. Suitable for longitudinal or interpolated machining on front and back faces of holes and surfaces.

Para las operaciones de super acabado la fresa **Bi-face-R** está provista de un perfil constante destalonado. Mecanizados longitudinales o por interpolación para el avellanado frontal o trasero de ángulos y agujeros.

双面锥形倒角刀具有连续表面，加工光洁度高。适合两面进行纵向或插补加工。孔和表面棱角

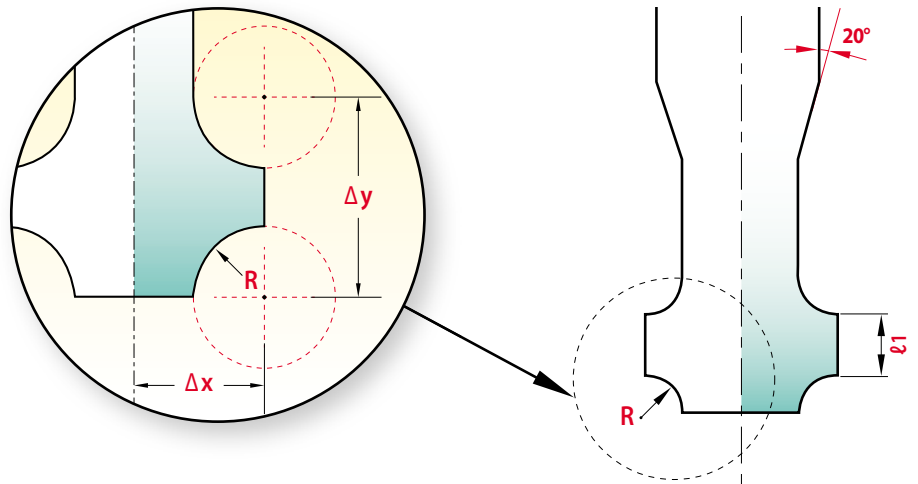
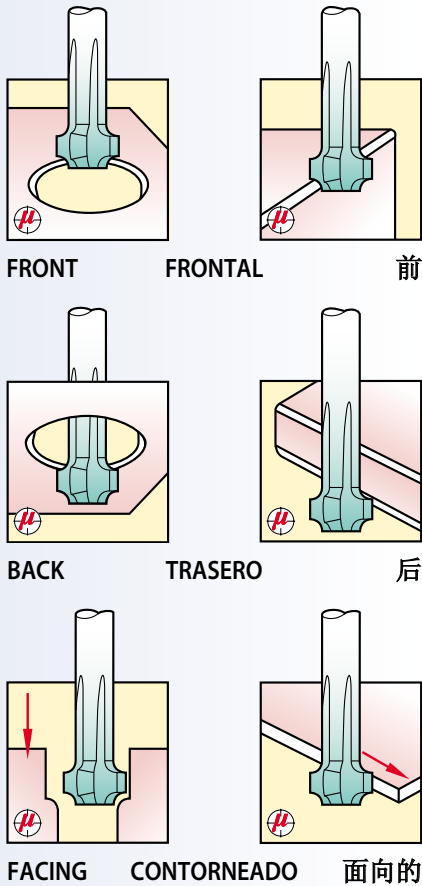

## FRONT AND BACK RADIUS CUTTERS

### FRESAS CON RADIO FRONTAL Y TRASERO

#### 正，反面 倒角刀

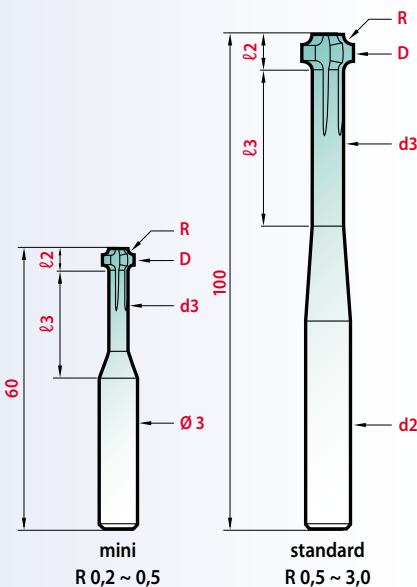

*New*



Bi-face-R mini							2 flutes			labios 刃	
R	D	d3	d2	Δx	Δy	ℓ1	ℓ2	ℓ3	Bi-face 848-R	Hard'X 848-RH	
± 0,02	maxi	maxi	h5						€	€	
0,2	1,9	1,25	3	0,87	1,32	0,90	1,45	8	•	•	
0,3	2,3	1,45	3	1,07	1,82	1,2	1,95	9	•	•	
0,4	2,6	1,55	3	1,22	2,37	1,55	2,5	10	•	•	
0,5	2,9	1,65	3	1,37	2,87	1,85	3	12	•	•	

Bi-face-R							3 flutes			labios 刃	
R	D	d3	d2	Δx	Δy	ℓ1	ℓ2	ℓ3	Bi-face 849-R	Hard'X 849-RH	
± 0,02	maxi	maxi	h5						€	€	
0,5	4,9	3,65	6	2,37	3,17	2,15	3,3	20	•	•	
0,6	5,20	3,75	6	2,52	3,37	2,14	3,5	25	•	•	
0,8	5,9	4,05	6	2,89	3,77	2,14	3,9	30	•	•	
1,0	6,6	4,35	8	3,22	4,27	2,23	4,3	35	•	•	
1,2	7,4	4,75	8	3,62	5,07	2,63	5,2	35	•	•	
1,5	8,4	5,1	10	4,12	5,77	2,73	5,8	35	•	•	
1,8	9,3	5,4	10	4,57	6,37	2,72	6,4	35	•	•	
2,0	9,9	5,6	10	4,87	6,87	2,82	6,8	35	•	•	
2,5	10,9	5,6	12	5,37	7,97	2,90	7,8	35	•	•	
3,0	11,9	5,6	12	5,87	9,07	3,0	8,8	35	•	•	