

# Long Largas 加长型

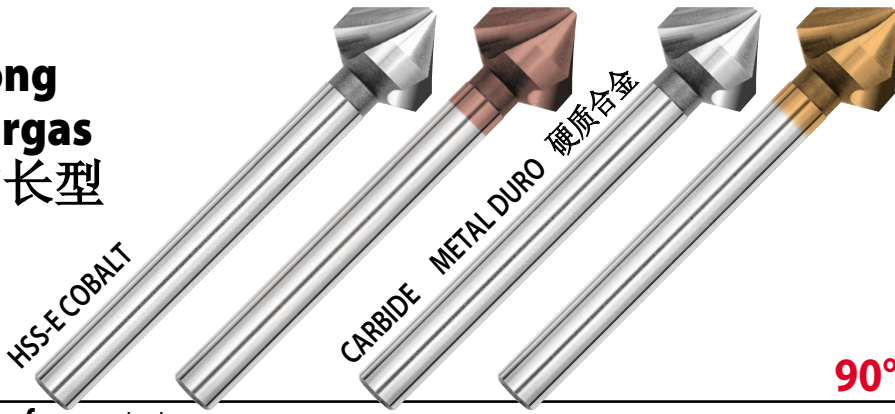

magafor standard

D z9	d1 maxi	d2 h9	L ± 1	magafor <b>4303</b>	Red'X <b>4933</b>	magaforce <b>8431-L</b>	Hard'X <b>8431-LH</b>
6,3	1,5	6	84	€ •	€ •	€ •	€ •
8,3	2,0	8	85	•	•	• *	• *
10,4	2,5	10	87	•	•	• *	• *
12,4	2,8	10	108	•	•	• *	• *
16,5	3,2	12	112	•	•	• *	• *
20,5	3,5	12	115	•	•	• *	• *
25,0	3,8	12	118	•	•	• *	• *

\* 3 flated shanks Mango con 3 planos 三面削平柄

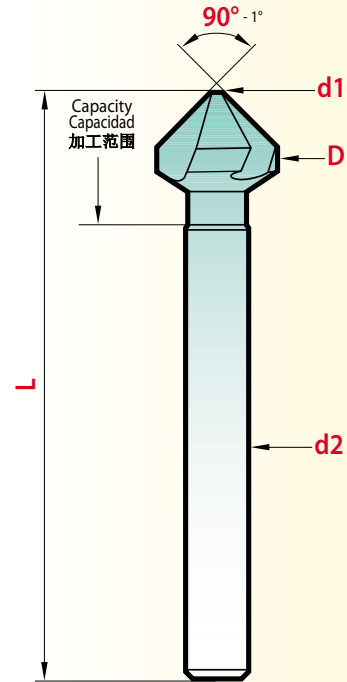

# Long / X-Long Largas / X-largas 长型 / 超长型

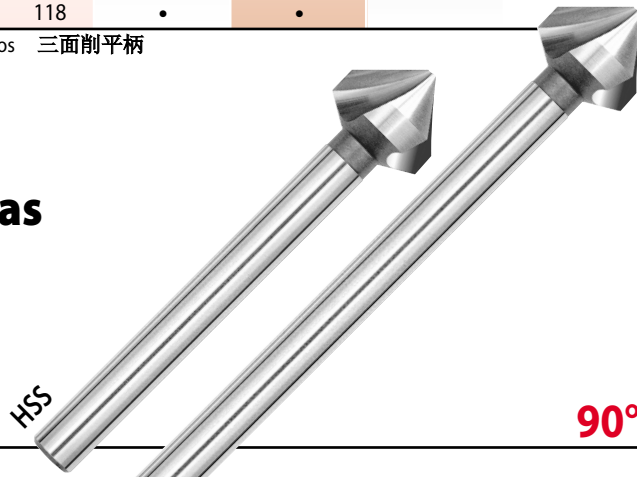

magafor standard

D z9	d1 maxi	d2 h9	L ± 1	Classic <b>4307-L</b>	L ± 1	Classic <b>4307-XL</b>
5,8	1,5	5	104	€ •		€
6,3	1,5	5	104	•	154	•
8,3	2,0	6	105	•	155	•
10,4	2,5	6	107	•	157	•
12,4	2,8	8	108	•	158	•
15,0	3,2	10	109	•	159	•
16,5	3,2	10	111	•	161	•
20,5	3,5	10	114	•	164	•
25,0	3,8	10	118	•	168	•

**magafor, The choice! La elección! 推荐表**

Video on line  
www.magafor.com



Material 材质 Material	HSS	HSS-Co	HSS-Co + TiN	HSS-Co	HSS-Co + Red'x	CARBIDE 硬质合金 METAL DURO	CARBIDE METAL DURO + Hard'X
Hardness 硬度 Dureza	63 HRC	65HRC	65 HRC + 2300 HV	65 HRC	65 HRC + 3500 HV	1800 HV	1800 HV + 3500 HV
Use Utilización 用途	Small series Pequeñas series 小批量加工	Intensive production Producción intensiva 大批量加工		Hard and abrasive alloys Aleaciones duras y abrasivas 硬而耐磨合金		Treated steels Aceros tratados 淬火钢	
Page Página 页	45 ~ 47	45 ~ 47		46		46 - 48	